

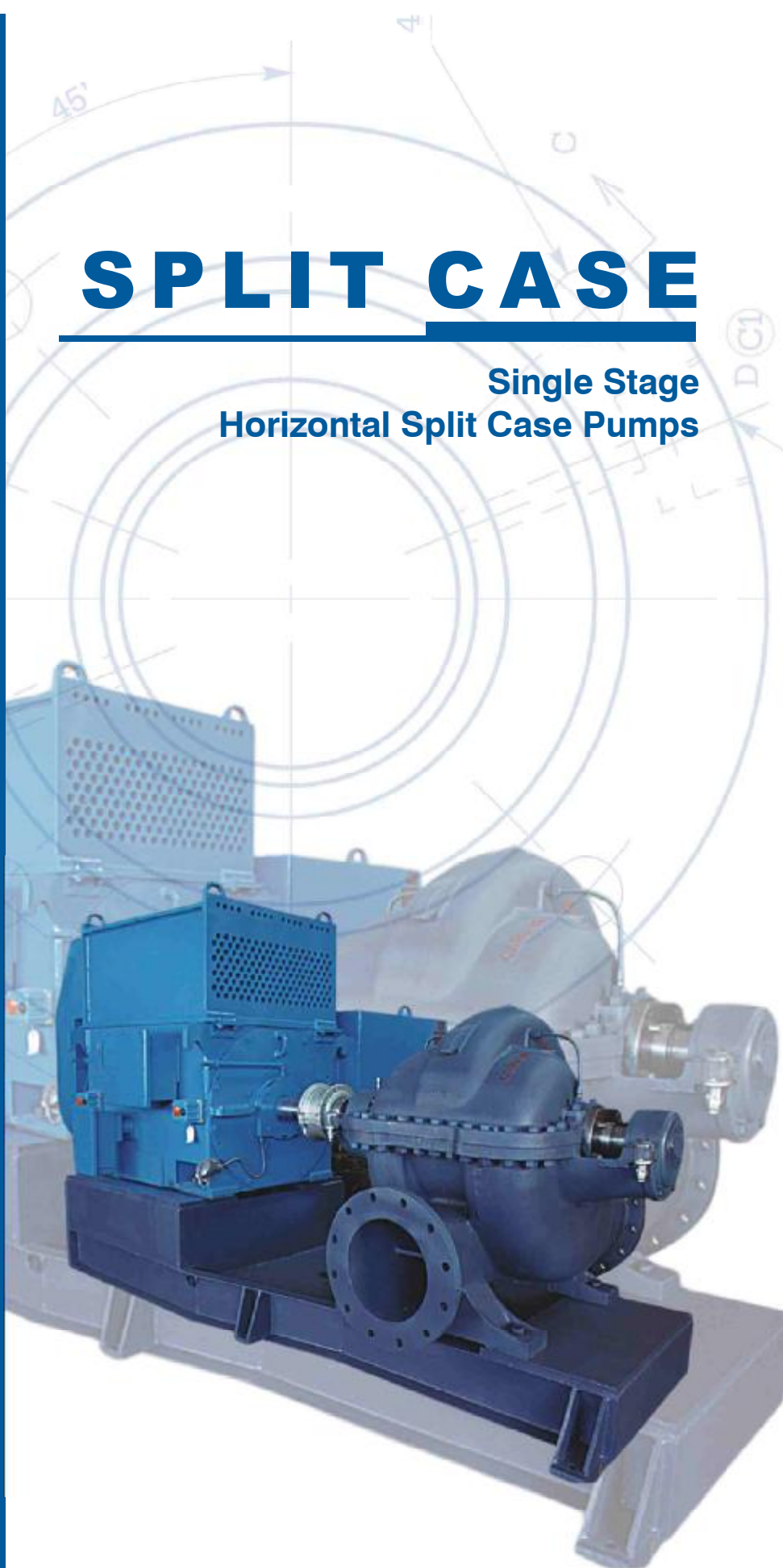

SPLIT CASE

Single Stage
Horizontal Split Case Pumps



SPLIT CASE

Horizontal Pumps

For over 50 years the name Ruhrpumpen has been synonymous worldwide with innovation and reliability for pumping technology.

The pump is a horizontal, single stage, double suction, double volute axially split case centrifugal pump. The suction and discharge nozzles are integrally cast in the lower half of the casing and on the same horizontal centerline. The nozzle configuration is side/side.

Intensive research and development ensures that the products of Ruhrpumpen are continuously improved to meet the latest technical requirements.

It is only possible to achieve these aims by means of highly sophisticated CNC controlled machines in our modern machine shop, supplemented by our test and

development departments as well as the latest industry standard inspection and control procedures. All in our ISO 9001 certified facilities.

The application of modern, reliable methods, data processing and sophisticated software with high performance, decentralized computers and personal computers offers our customers high reliability and speed in all working processes, from planning and production to the providing of spare parts.

The instant availability of spare parts, together with first class service, ensures customers that they have selected the right partner.

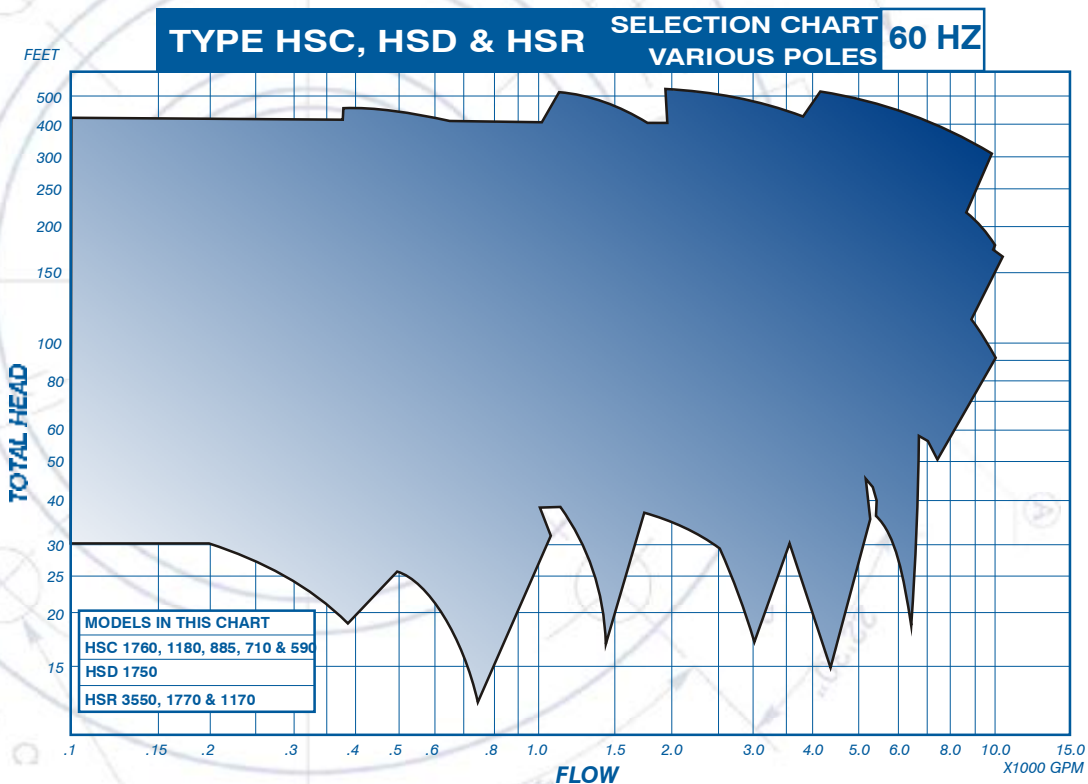

SPLIT CASE



Horizontal Split Case Pumps

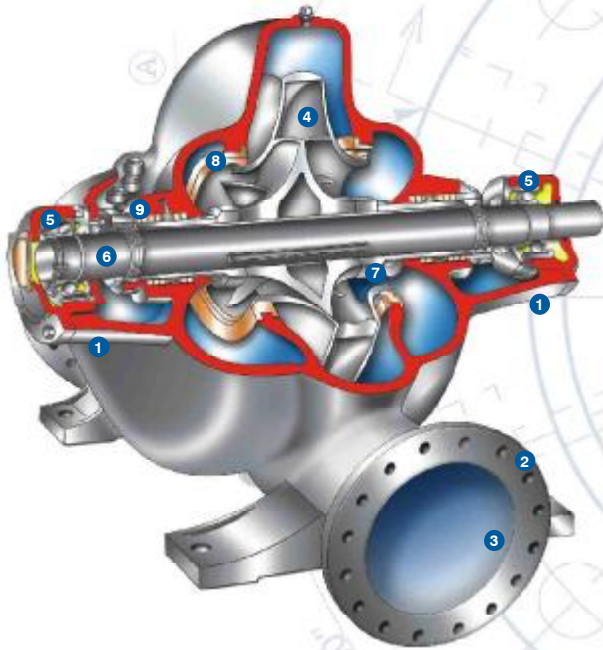

- 1 Bearing Brackets are cast integral with the casing - assuring perfect alignment.
- 2 Suction and discharge connections all on the same center line - for piping ease.
- 3 Smaller discharge diameter - reduces the cost of piping and valves - allowing more compact installation.
- 4 All impellers are dynamically balanced - for vibration-free operation.
- 5 Interchangeable line and thrust bearings, conservatively rated at 100,000 hrs "plus" bearing life - guarantee maximum life at minimum maintenance cost. Either oil or grease lubrication available.
- 6 Rigid shaft combined with double - volute casing - results in low shaft deflection at all operating points. Low deflection reduces packing wear, ring wear and bearing loading, which ultimately results in sustained efficiency and economy of operation.
- 7 Packing sleeve is keyed to shaft and held in place by separate shaft nut. This Ruhrpumpen feature provides the greatest simplification of sleeve replacement. Sleeves are sealed to shaft by an "O" ring to prevent leakage and subsequent erosion. 11-13% Chrome Sleeves are available for extended sleeve life on packing.
- 8 Casing wear rings are standard and renewable on all pumps.
- 9 Stuffing box option. Packing or mechanical seals can be furnished.
- 10 Many sizes available with side or bottom suction - for installation flexibility.

Product Description

- ✓ Single stage horizontal centrifugal pump.
- ✓ Horizontally split case, double volute (HSC pumps, and some HSR's) minimizes thrust loads and allow operation over a wide range of capacities.
- ✓ Flanged connections.
- ✓ Enclosed impellers, double suction provides hydraulic balance eliminating axial thrust.
- ✓ Clockwise or counter clockwise rotation.
- ✓ Oil lubrication bearings.
- ✓ Stuffing box allows for mechanical seal.
- ✓ Horizontal or vertical mounting arrangements are available.

Broad Application Range

- ✓ Cooling towers.
- ✓ Municipal.
- ✓ Oil process.
- ✓ Petrochemical.
- ✓ Sugar Industry.
- ✓ Paper Industry.

Performance Data

Capacity	To 63000 U.S. gpm	14318m ³ /hr
Head	To 550 feet	168 m
Pressure	To 400 psig	
Temperature	50° F to 300° F	

Other Ruhrpumpen Products

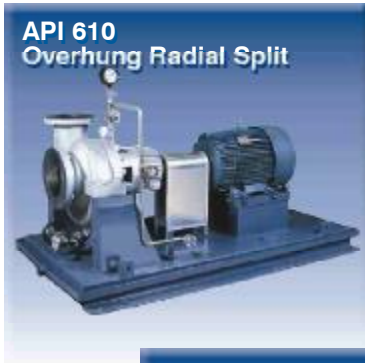

Ruhrpumpen, Inc.
4501 South 86th East Ave.
Tulsa, Oklahoma 74145 USA
Phone: 918-627-8400
Fax: 918-624-2471
e-mail: info@ruhrpumpen.com

Ruhrpumpen GmbH
Stockumer Strasse 28 58453 Witten/Germany
P.O. Box 63 09 58432 Witten/Germany
Phone: (+ +49) 23 02/661-03
Fax: (+ +49) 23 02/661-3 03
e-mail: info@ruhrpumpen.de

Ruhrpumpen, S.A.
Níquel No. 9204 Ciudad Industrial Mitras,
García, N.L. México 66000
Phone: (+52)(81) 8158-5500
Fax: (+52)(81) 8158-5501
e-mail: wdm@corporacioneg.com

www.ruhrpumpen.com
e-mail: info@ruhrpumpen.com

A/May/03



Specialist for Pumping Technology

A
Corporación 
Company

For more information:

